

FLANGE DIAGRAM

G35-900 G35-1050

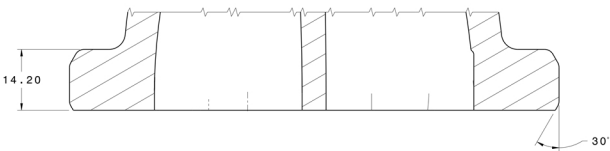

TURBINE INLET
T4 BOLTED CONNECTIONS

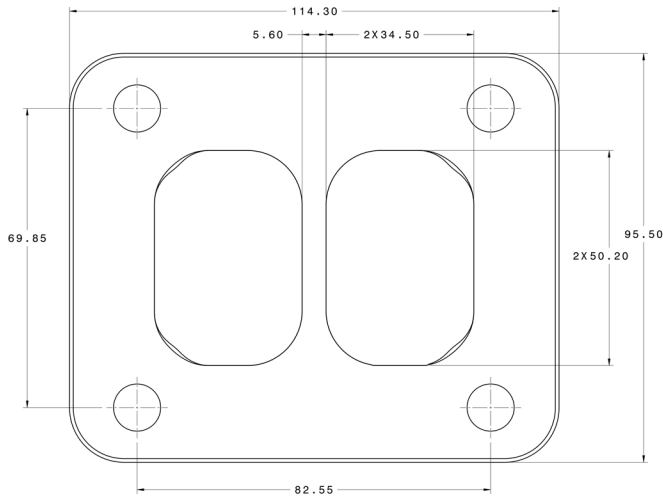
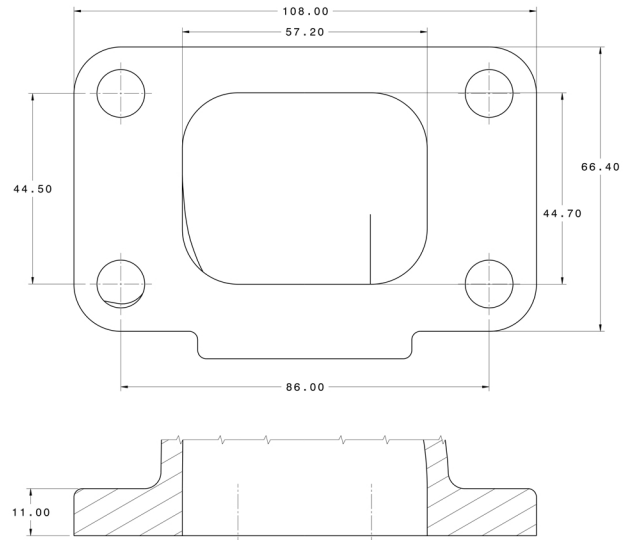

TURBINE INLET
T3 BOLTED CONNECTIONS

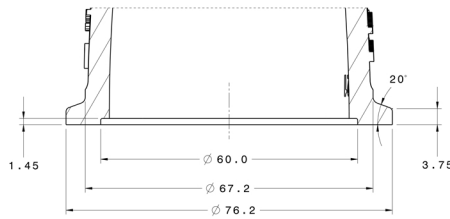

TURBINE INLET
V-BAND CONNECTIONS

TURBINE OUTLET
V-BAND CONNECTIONS

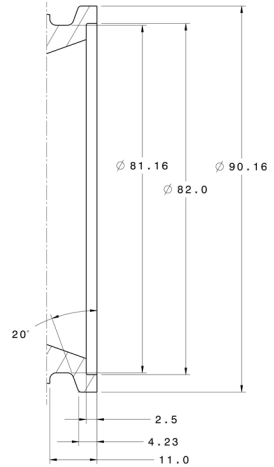

OIL INLET
-4AN FITTING CONNECTION

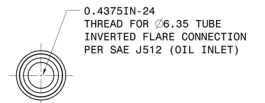

OIL OUTLET

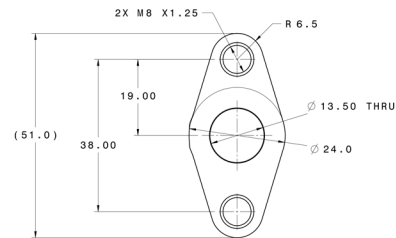

WATER
M14 X 1.50
-6AN FITTING CONNECTION

COMPRESSOR INLET

HOSE CONNECTIONS
G3576/ ∅100.00 X 25.40
G3584 ∅101.60 X 25.40

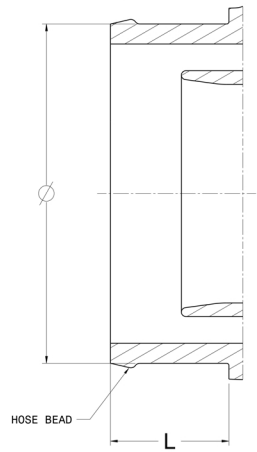

COMPRESSOR OUTLET

HOSE CONNECTIONS
G3576/ ∅50.80 X 29.00
G3584 ∅63.50 X 26.00

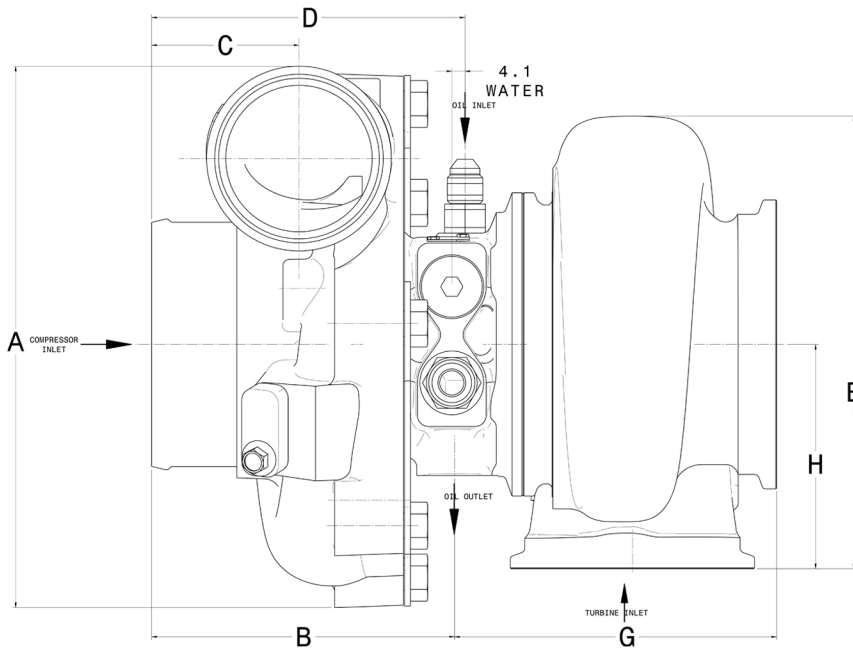
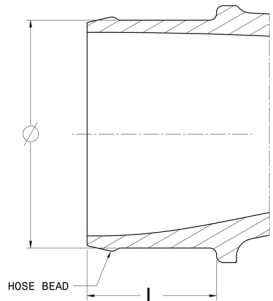

MEASUREMENTS IN MM

	COMPRESSOR		TURBINE										
	G35-900	G35-1050	A/R (INLET)	0.61 (VBAND)	0.83 (VBAND)	1.01 (VBAND)	1.21 (VBAND)	0.83 (T3)	1.01 (T3)	1.06 (T4)	1.01 (T4)WG	0.83 (VBAND)WG	1.01 (VBAND)WG
A	189.8	202.9	E	146.1	151.6	156.3	159.6	159.6	164.5	183.3	175.9	151.8	156.2
B	93.3	102.2	G	100.5	100.5	100.5	100.5	113.6	113.6	103.1	147.9	136.3	136.3
C	44.7	52.6	H	70.0	70.0	70.0	70.0	80.0	80.0	88.5	82.0	70.0	70.0
D	96.5	105.5											